

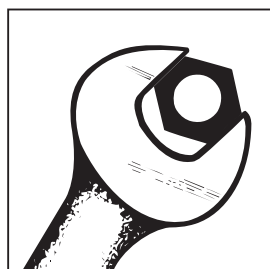

DISHWASHERS ECOMAX 802

INSTALLATION



OPERATION

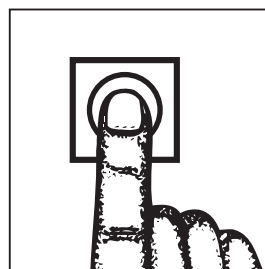

IMPORTANT NOTES

GB

Use in Accordance with Regulations

This machine is only intended for cleaning dishes, plates, cups, glasses, cutlery, trays etc.
Do not use for electrically heated cooking and heat conservation appliances.

Safety

Never hose down the outside of the machine.



The "**Attention**" symbol is shown beside instructions that are essential for the **safe operation** of the machine.
Please read these passages thoroughly.

Liability

Installations and repairs which are carried out by **non authorized technicians** or the use of **other than original spare parts**, and any **technical alterations** to the machine, **may affect the warranty set out in the standard conditions of sale.**

Important

This Instruction manual is written for machines with an operating direction from left to right.
For machines with an operating direction from right to left, the same information applies but with opposite handling directions.

Machine noise level:

The machine noise level is ≤ 70 dB (A).

1 ASSEMBLY	4
1.1 Transport to installation location	4
1.2 Remove packing	4
1.3 Locating	4
1.4 Adjusting machine height	4
1.5 Attach dish rack tables and accessories	5
2 CONNECTIONS	6
2.1 Electrical connection	6
2.2 Water connection	7
2.3 Dispensers for detergent and rinse aid	8
3 CONTROLS	9
4 FIRST RUN	10
4.1 Preparation	10
4.2 Filling the rinse booster heater	10
4.3 Check	10
5 OPERATION	11
5.1 Preparation	11
5.2 Racking	12
5.3 Washing	13
5.4 Stand-By operation	13
5.5 Machine - OFF	13
6 CLEANING THE MACHINE	14
7 POSITION OF CURTAINS	16
8 FROST PREVENTION	17
9 MAINTENANCE	17
10 TROUBLESHOOTING	18

1 ASSEMBLY

SHOULD BE CARRIED OUT BY HOBART TECHNI-

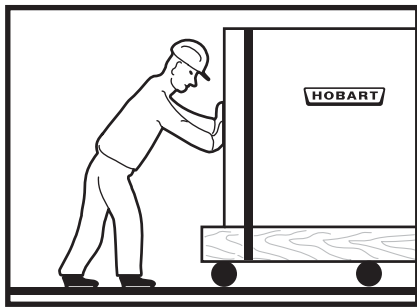

1.1 TRANSPORT TO INSTALLATION LOCATION

- If possible in its packing and on skid.
- Push on rollers.
- Avoid damage to floor, doors and to the machine.
- If a fork lift is used, put a wooden frame under the machine.

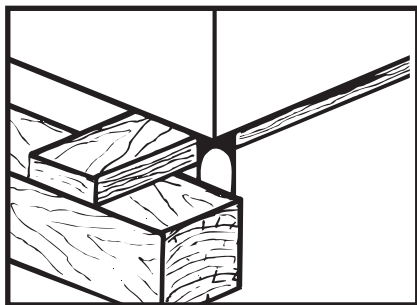

1.2 REMOVE PACKING

- Cut steel bands.
- Remove carton.
- Remove wooden skid.
- Remove inside packing material and accessories.



1.3 LOCATING

- According to the installation plan.

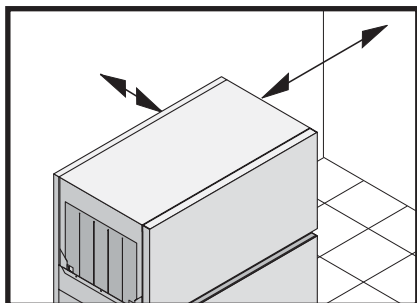

- Consider wall clearance according to the installation plan (normally 44 mm).
- Consider length of tabling, etc.

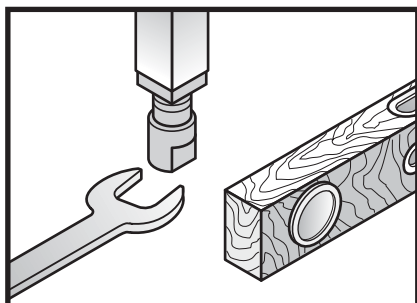

1.4 ADJUSTING MACHINE HEIGHT

- Level floor unevenness.
- Distribute machine weight equally onto all feet.

1.5 | ATTACH DISH RACK TABLES AND ACCESSORIES

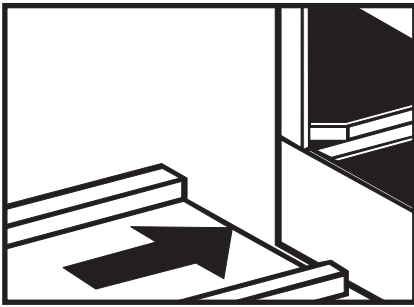

- See separate instructions.
- Seal screw holes.

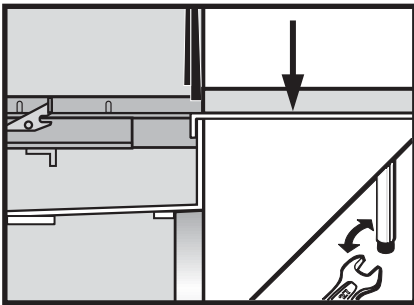

- Allow a slight inclination to the machine (if needed, adjust level by turning the feet).
- Pay attention that the rack track level of the machine is the same as the table or roller conveyor level.

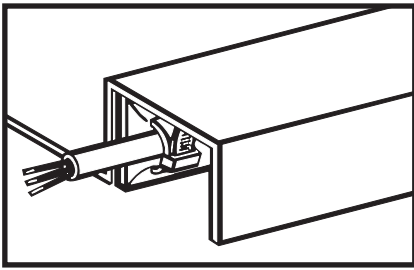

- **TABLE END SWITCH:**
Wiring to control box must be protected.

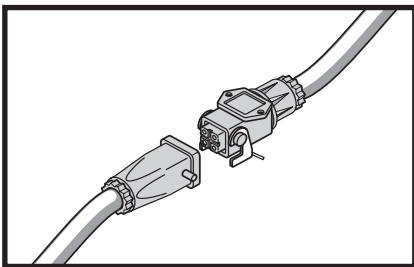

- **TABLES ON ROLLERS INCLUDING END SWITCH:**
Close the connector of the cable and lock it.

2 CONNECTIONS

GB

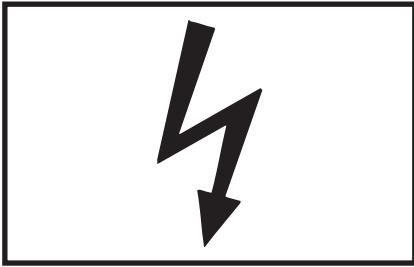

2.1 ELECTRICAL CONNECTION



Must be carried out by an authorized technician according to the national and local codes.

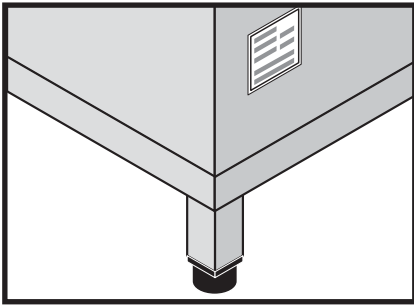

2.1.1 CHECK

- Remove lower front panel (unscrew), turn control box to front and take out wiring diagram.
- The electrical supply shall comply with the name-plate data and the wiring diagram.
- Line fuses and cable cross section shall comply with the requirements.

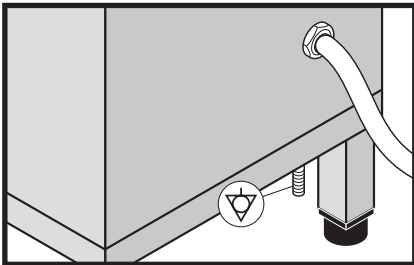

2.1.2 CONNECTION

- **The appliance is intended for a fixed electrical connection.**
- Draw cable (H07-RN-F) through cable gland in the side panel.
- Connect wires to the built-in main switch.
- Tighten all terminal screws (may be loosened during transport).
- Tighten the cable gland.

According to EN 60 335 the appliance must be connected to an equipotential conductor.

The connecting screw (▽) is located beside the cable inlet.

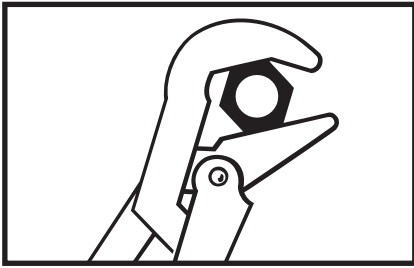

2.2 | WATER CONNECTION



Must be carried out by an authorized technician according to the national and local codes.

The machine must be operated with potable water.
For water with an extremely high mineral content an external demineralisation is strongly recommended.

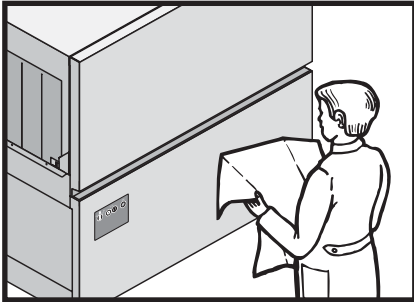

2.2.1 | GENERAL

- Connect water supply and drain pipes according to installation plan.
- Class A air gap is fitted to the machine as standard.

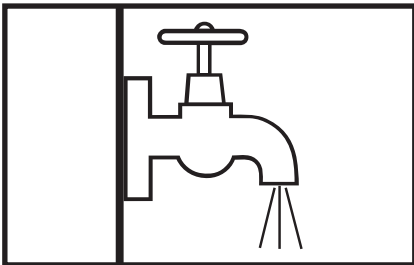

2.2.2 | FRESHWATER SUPPLY DN 20 (G3/4")

- Should be soft (up to 4° Clark, resp. 0.5 mmol/l).
- Line flow pressure 1.5 - 6 bar at ~500 l/hr.
- Provide shut-off valve and line strainer at site.

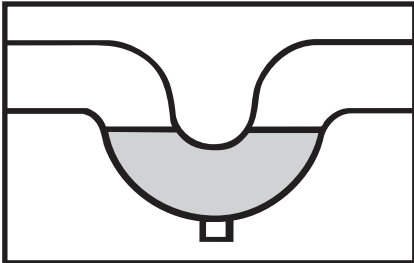

2.2.3 | DRAIN CONNECTION

To be connected to site drain:

- Tank drain DN 50 (HT Pipe).
- Drip water drains of tabling, sink and other elements.
- All drains must be connected to goose neck (individually or single point).

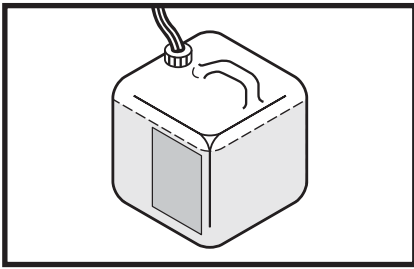

2.3 DISPENSERS FOR DETERGENT AND RINSE AID

- Normally dispensers and controls are delivered and installed by the detergent and rinse aid suppliers.
- Install dispensers, controls and containers such that they are easy to handle and do not disturb machine operation.
- Rinse aid connection (A) is provided above the rinse booster heater (R 1/8" inside).
- Terminals (230V~) are provided in the control box (see wiring diagram).

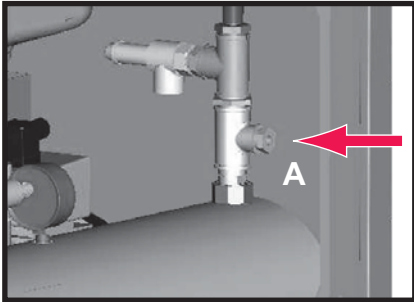

Please see separate installation instructions.

It is recommended that dispensers and their controls are not fitted directly to the machine! (The panels have thermal insulation.)

Use only commercial detergent and rinse aid (suitable for professional and industrial operations).

Please pay attention to the manufacturers safety instructions.

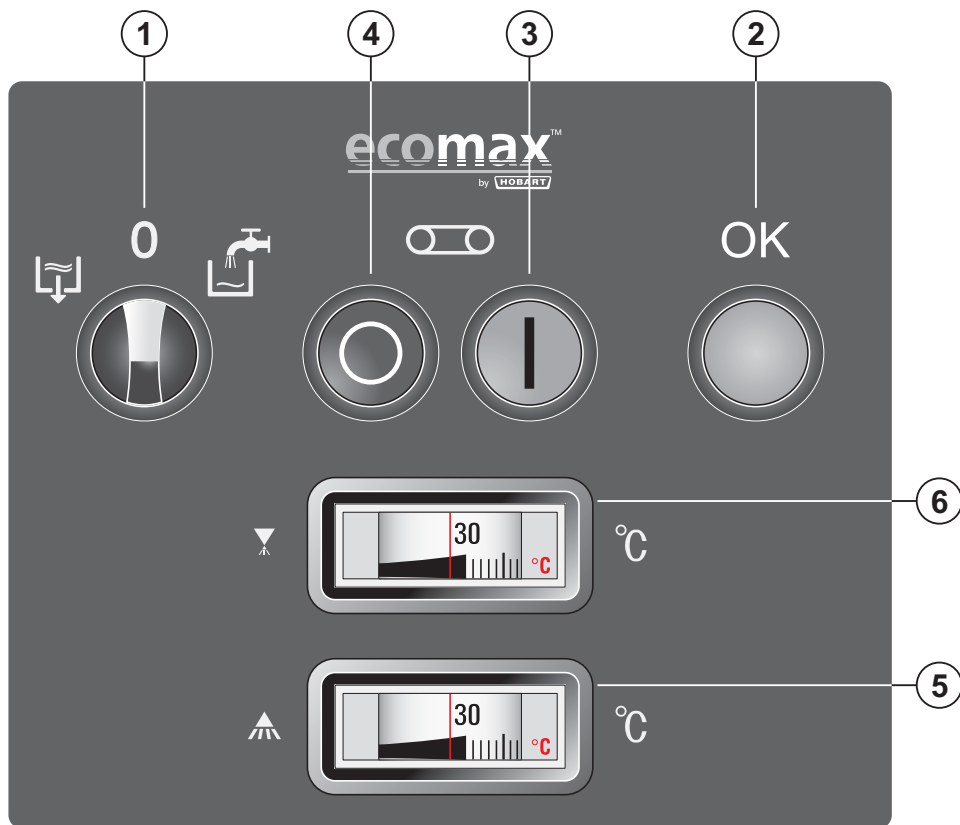

- ① **Program selector switch** (illuminates during operation)
 By turning the selector switch to **Fill position**, the machine will be switched on automatically and filled up (tank heating and rinse booster heater start automatically).
 By turning the selector switch to **0 position**, the machine (heating and conveyor) will be shut off (e.g. during long term interruption).
 By turning the selector switch to **Drain position**, the machine will be emptied (e.g. end of operation).

- ② **OK pilot light** (green)
 Indicates that the machine is ready for operation.

- ③ **Conveyor ON** button
 By pushing this button conveyor and wash operation start.

- ④ **Conveyor OFF** button
 Pushing this button switches the conveyor and wash operation off ("**Stand-By**" Mode)

- ⑤ Temperature indicator **Wash** (°C)
 Indicates the current temperature of the wash tank.

- ⑥ Temperature indicator **Rinse** (°C)
 Indicates the current temperature of the final rinse water.



Must be carried out by an authorized Service technician to adjust and check machine functions !

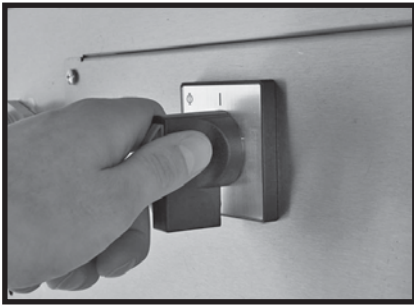

4.1 | PREPARATION

- Program selector switch ① must be set to "0" position.
- **Switch off main switch.**
- **Open shut-off valves.**
- Remove the lower front panel.
- Switch on all circuit breakers and motor protection switches in the control box.

4.2 | FILLING THE RINSE BOOSTER HEATER



Ensure that the conductor (1B1.12) at the thermostat (1B1) of the rinse booster is disconnected.

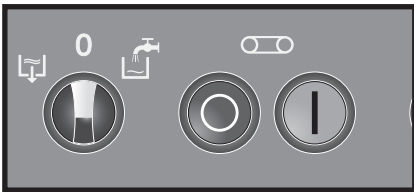
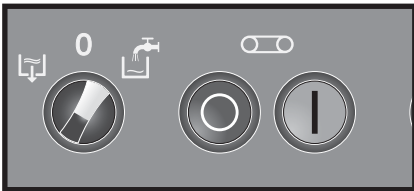

- **Switch on main switch.**
- Set the **program** selector switch ① to "Fill" position.
- Wait until water sprays out of the rinse arm nozzles.

- Set the program selector switch ① to "0" position.
- **Switch off main switch.**
- Connect the conductor (1B1.12) to the thermostate (1B1) of the rinse booster.
- Put the lower front panel in place.
- **Switch on main switch.**

4.3 | CHECK

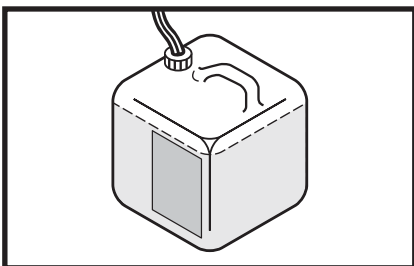
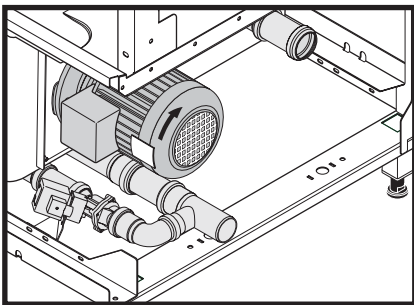

- Direction of rotation of motors (see direction sign):
 - Conveyor motor (both speeds)
 - Pumps
- If motor runs against the indicated direction, interchange 2 of 3 phases at the terminal.
- Check and eliminate potential leakages.
 - Drain
 - Heating pipework and water supply pipework
 - Machine housing, bottom of tanks, exhaust system
- Make sure detergent and rinse aid containers are filled. The adjustment should be done by the chemicals supplier.

5 OPERATION

GB

5.1 PREPARATION



Put the flat strainers in place.



Put the strainer baskets in place.



Place pump intake strainers in position at the bottom of wash tank (rinse section).



Put the rinse strainer in place.

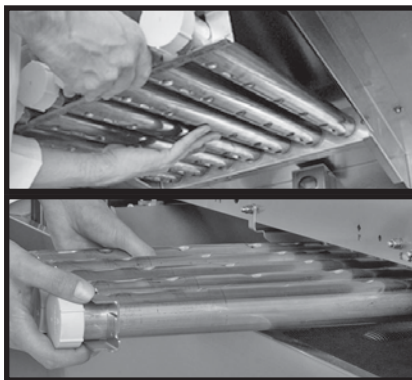

Set wash arms in place:
Upper: set wash arm in side guides, move to end position and drop-in over stop unit.
Lower: move wash arm in side guides to end position and click into place.

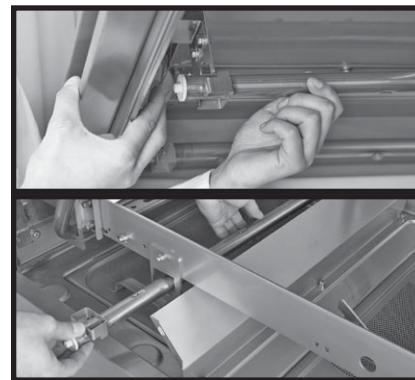

Set rinse arms in place:
Upper: set rinse arm in back opening, move from below into guide and click into place.
Lower: move rinse arm in guides to end position and click into place.



Put curtains in place (see chapter 7).



Close inspection doors. Ensure sufficient detergent and rinse aid is available in the right containers.



Switch on main switch. Open shut-off valve at site.

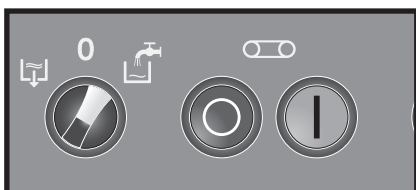

Set **program** selector switch ① to "Fill" position. The machine starts fill and heating automatically.

When the green pilot light "OK" ② illuminates, machine is ready for operation.

OPERATION

GB

5.2 RACKING (Remove coarse food soil before washing.)

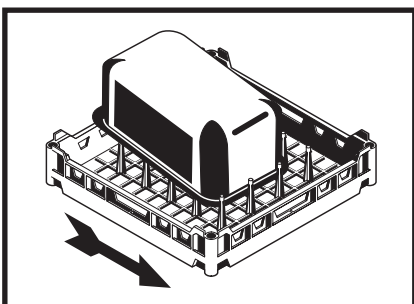
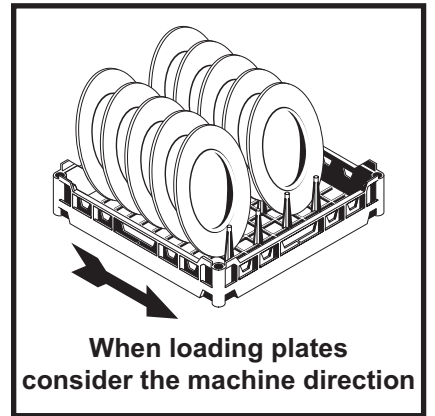
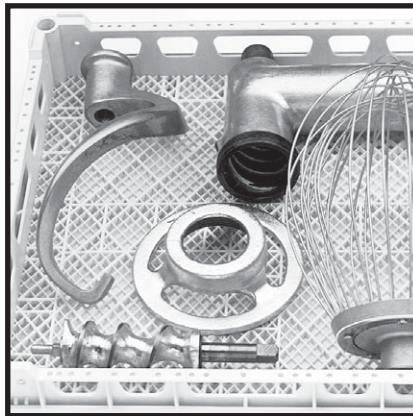
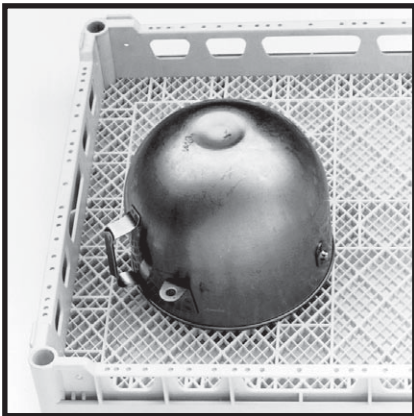
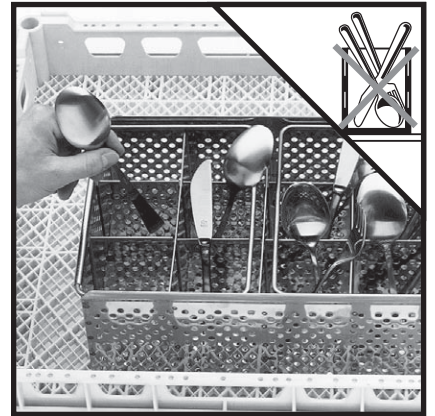
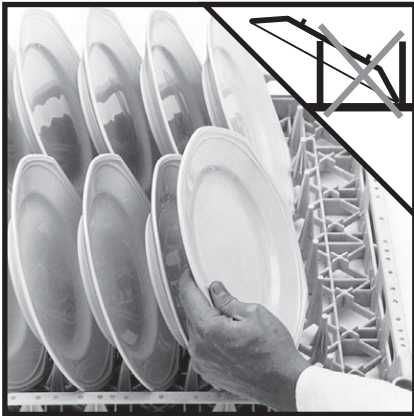
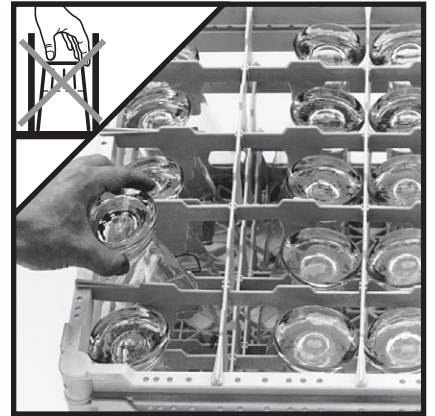

Gastronorm pans and other large containers or boards should ideally be washed in a separate Utensil Washer.

In Automatic Rack Type Dishwashers these items may cause problems such as splash-over leading to low water levels in the tank/s and poor rinsing.

On the occasions when these items are to be washed, they should be loaded sloping towards the direction of machine operation as shown in the picture. This will reduce the problems described above.

5.3 | WASHING

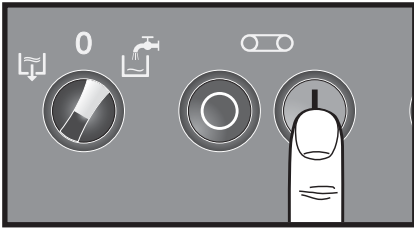

- By pushing the **Conveyor ON** button ③ the machine is ready for operation. Conveyor and wash will start.

This should only be done after the set temperatures have been reached and the green **OK** pilot light illuminates.

Give dishes enough time to dry after washing.

5.4 | STAND-BY OPERATION

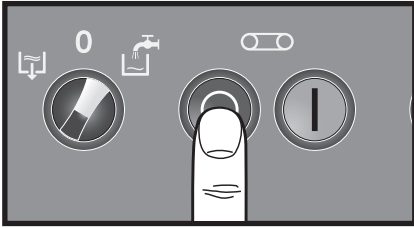

- When no further racks enter the machine, conveyor and wash can be switched off manually by pushing the **Conveyor OFF** button ④. The heaters run continuously.

- By pushing the **Conveyor ON** button ③ conveyor and wash will start again.

5.5 | MACHINE - OFF

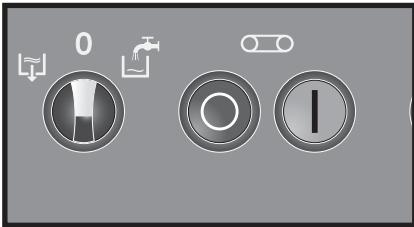

In case of operating error or faults it is possible, to switch-off the machine immediately without draining the tanks.

- Turn the **program** selector switch ① to "0" position.

6 | CLEANING THE MACHINE

GB

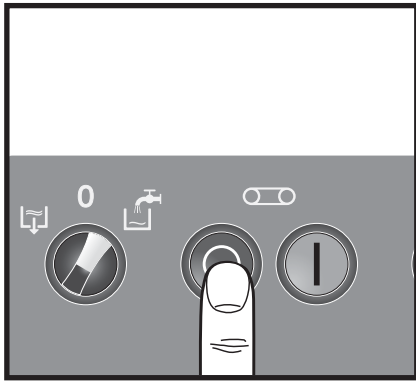

Push the **Conveyor OFF** button, conveyor and wash stop.

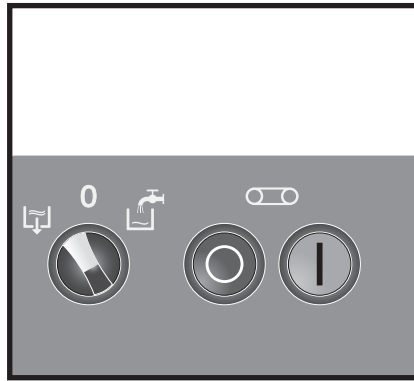

Turn the **program** selector switch to "**Drain**" position. The machine will be emptied. Exhaust and heaters stop automatically.

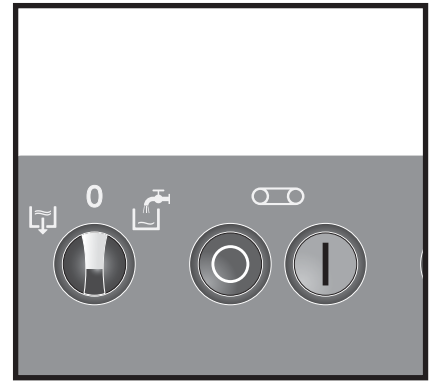

When all tanks are completely emptied, set the selector switch back to "**0**" position.



Switch off main switch.



Open the inspection doors.



Take out an clean curtains.



To clean the machine do not use any chloric, acidic or abrasive products and no metallic brushes. Never hose down the exterior of the machine.

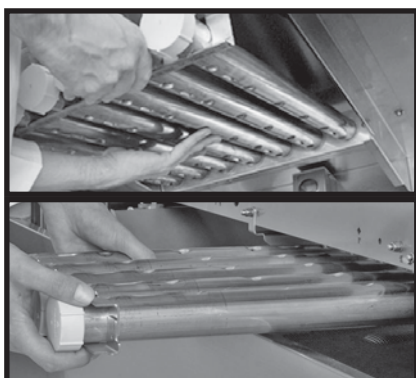

Remove wash arms:
Upper: Lift wash arm over stop unit and pull out.
Lower: Lift wash arm to pull out.



Remove end caps and clean wash arms accurately.

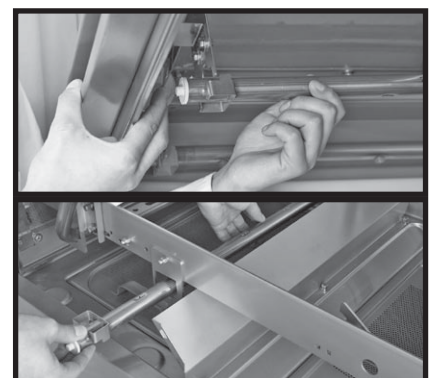

Remove rinse arms:
Upper: pull spring towards front and remove rinse arm.
Lower: lift rinse arm and pull out. Control nozzle openings and clean if necessary.

CLEANING THE MACHINE

GB



Remove strainer baskets.

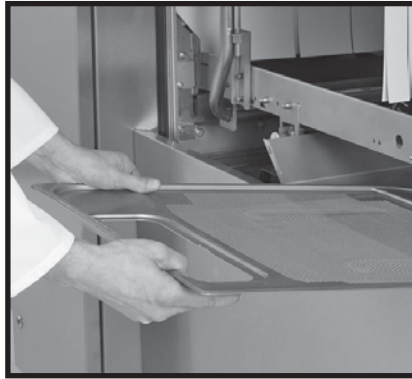

Remove flat strainers.



Remove rinse strainer.



Hose down and brush the strainers – do not knock them to dislodge food soil! They could be damaged.



Remove pump intake strainer (rinse section).



Hose down and clean the interior of the machine (particularly the bottom of wash and prewash tank) to avoid any waste remaining.

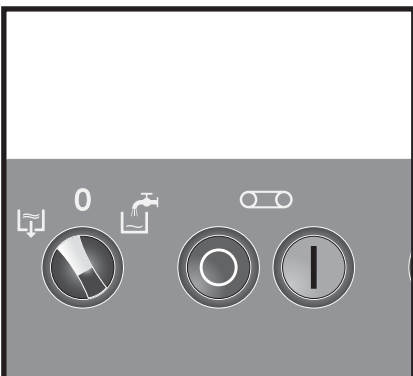

To drain the tanks, switch on main switch and set program selector switch to "**Drain**" position. The drain valves will be opened again. Wait until the tanks are completely emptied and set the selector switch back to "**0**" position.



Wait until the tanks are completely emptied and set the selector switch back to "**0**" position.



Switch off the main switch and close shut-off valve(s) at site.

Leave the inspection doors open for ventilation.

7 POSITION OF CURTAINS

GB

The working direction as shown is left/right.
On working direction right/left the position of curtains is reversed.

CURTAINS

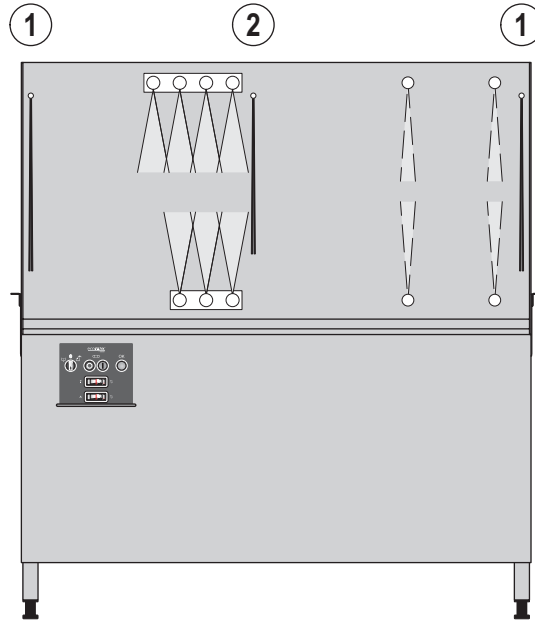
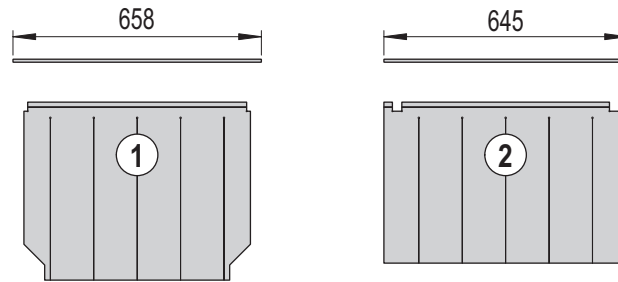

8 | FROST PREVENTION



Must be carried out by an authorized Service technician!

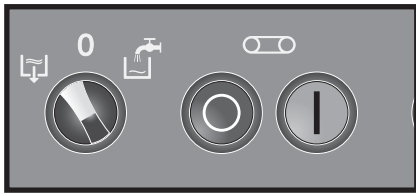

- Drain machine (start drain cycle).
- **Set main switch to "0".**
- Close shut-off valve(s) at site.
- Unplug the connecting wire (**1B1.12**) from the thermostat (**1B1**).

All tanks, water pipework and armatures must be totally drained.

- Remove plug at the bottom of the rinse booster heater.
- Loosen the union behind the non-return valve.
- Drain site water pipework.
- Drain traps of drain system.
- **Reset for operation according to chapter 4.**

9 | MAINTENANCE



For trouble free operation we recommend an inspection or maintenance contract by qualified Service technicians.

10 | TROUBLESHOOTING

GB

FAULT	CAUSE	REMEDY
Initial booster fill not possible.	Shut off valve at site closed.	Open the shut off valve at site and restart.
	Fill system defective.	Call the after sales service.
Tank fill too slow.	Line strainer of fill clogged.	Clean line strainer.
	Solenoid valve defective.	Call the after sales service.
	Shut off valve at site not correctly open.	Open shut off valve completely.
Tank not filled to correct level.	Fill cycle too short.	Call the after sales service.
Temperatures too low.	Heaters defective.	Check heaters, steam or high pressure hot water supply systems. If necessary, call the after sales service.
Washware soiled after dishwashing.	Strainers wrongly positioned.	Check strainers.
	Curtains not fitted or wrongly placed.	Check curtains (see chapter 7).
	Wash arm nozzles clogged.	Clean the wash arms.
	Too low detergent concentration.	Increase detergent dispensing.
	Too much foam.	Use non-foaming detergent only.
	Excessive food debris entering machine.	Check pre-scraping procedure.
	Temperatures too low.	Check heating system.
Streaks and spots on washware.	Wash / Rinse fault.	Call the after sales service.
	Strainers wrongly positioned.	Check strainers.
	Wash water splashes into rinse section.	Check curtains (see chapter 7).
	Rinse nozzles clogged.	Clean rinse nozzles.
	Incorrect rinse aid dispensing.	Adjust rinse aid dispenser.
Washware do not dry.	Too high mineral content of rinse water.	Use of demineralized water recommended.
	Inadequate rinse aid concentration.	Increase concentration.
Drops on washware.	Wrong rinse aid or inadequate concentration.	Check rinse aid / adjustment.
Dishes tilt over.	Water pressure from below too high.	Call the after sales service.
	Upper wash arms clogged.	Remove wash arms and clean.

As continued product improvement is a policy of HOBART, specifications are subject to change without notice.